

### Double Roll Closer System

The Fischbein Model DRC 300 Double Roll Closer seals multi-wall, flush-cut paper bags weighing up to 50 pounds at production rates up to 75 linear feet per minute. The Model DRC 300 automatically trims the top of the bag, makes a single precise fold, applies hot melt adhesive, and then makes a final second fold. The patented breakaway design eliminates costly downtime caused by bag jams while allowing easy cleaning and service of the bag folder.



#### APPLICATIONS

- Fertilizers
- Agricultural Seed
- Chemicals
- Cat Litter
- Powdered Dairy Products
- Food
- Feed Additives
- Snack Foods
- Minerals
- Pet Food

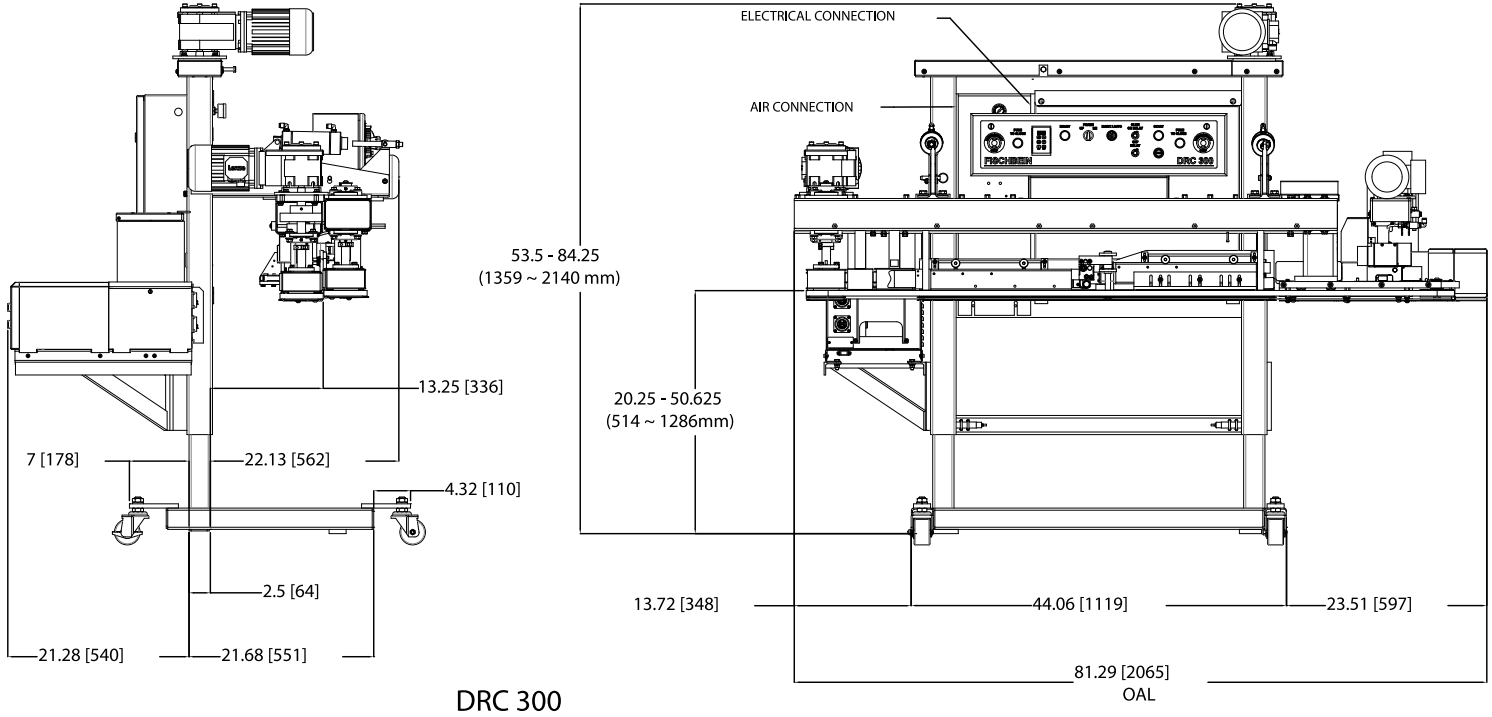

## FEATURES

- Closes multi-wall paper bags.
- Spiral glide folder technology creates bag closures that are consistent, reliable and attractive.
- A patented breakaway design eliminates costly downtime caused by bag jams, while allowing easy cleaning and service of the bag folder.
- Safe and easy to use control panel with digital temperature control and display key pad for variable speed control, and dual emergency stop buttons.
- Right to Left operation
- Dynatech Hot Melt Adhesive Applicator
- Dual Knife Bag Top Trimmer

## OPTIONS

- Additional motor starter and contractor for conveyor
- Left to right operation
- CR Plus 2 part corrosion resistant
- Nordson brand hot melt application system
- Wide fold for larger bags - Model 300 Plus
- 575 VAC

## SPECIFICATIONS

- Dimensions: W 82in (208cm), D 46in (120cm), H 54 - 85 in (216cm)
- Speed: Up to 75 linear feet per minute
- Electric (NEMA 12): 230V-3PH 50/60Hz, 24 VAC
- Air: 8 cfm @ 80-100 PSI

## BAGS

- Bag Types: Open mouth flat or gusseted multi-wall paper bag.
- Bag Face Width: Minimum 5 in (12.7 cm)
- Free Bag Top: Minimum 6 in (15.2 cm) Standard fold minimum 7.5 in (19cm) widefold