



## MODEL A

Magnum Systems' Model-A Packers are pneumatic-aeration packers designed specifically for powders and powder mixes, such as flour, cement, and chemicals. They also effectively handle granular materials. The Model-A was the first air packer with precise bulk and dribble fill cycles.

### PACKAGE POWDER AND POWDER MIXES WITH SPEED AND PRECISION

#### Features

- Regenerative blower
- Pneumatic bag clamp
- Pneumatic bag kicker
- Fill spout cutoff gate
- 4,000 cubic inch product hopper
- T-4000 weigh controller with digital readout

#### Optional Features

- Stainless steel construction/contact areas
- Spout filling station with chair for operator
- TRV-1000 robotic bag placer
- TRUSeal ultrasonic sealer
- Integrate conveying and palletizing equipment

#### Materials Typically Handled

- Sugar (powder and granular)
- Flour
- Cement
- Various oxides
- Refractory mixes
- Fine resins



One Partner For All Your Material Handling Needs.

# VALVE BAG AIR PACKER

FRONT VIEW

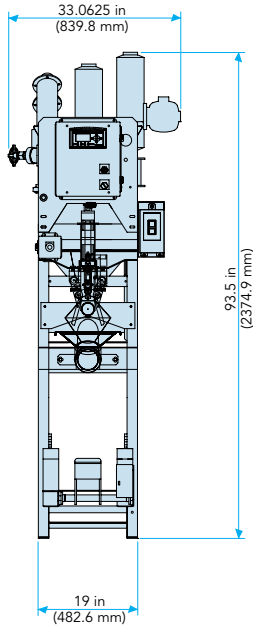

RIGHT-SIDE VIEW

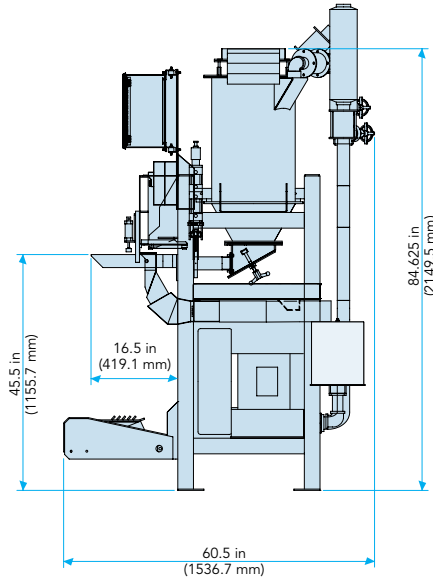

TOP VIEW

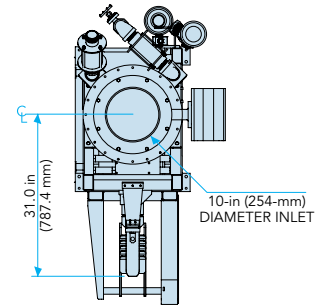

Diagram dimensions are for reference only\*

## SPECIFICATIONS

Speed	Up to 8 BPM/spout
Accuracy	Up to 0.4%
Bag Weight Range	15 to 125 lb (6.8 to 56.7 kg)
Construction	Tubular carbon steel blasted and painted
Product Hopper	4,000 cubic inch (6,550 cubic centimeter) capacity (standard)
Spout Size	1.5-in (3.81 cm) diameter
Electrical Requirements	230/460 volt, 3 phase, 60 Hz (blower); 115 Volt, 1 phase, 60 Hz (control voltage)
Air Requirements	90 PSI (6.2 BAR) 2 cubic feet (0.057 cubic meter) per cycle



### ULTRASONIC SEALER

- Ultrasonic waves alter molecular structure of sealing agent without heat, which reduces product degradation
- Rigid mount setup at filling source decreases amount of bag movement while maintaining bag shape
- Ultrasonic waves displaces product from seal area providing a clean, positive seal
- Helps prevent product loss during shipping
- Capable of both plastic and paper valve sealable bags
- Works well with dusty, fluid, powder, and hygroscopic products



©2024 Magnum Systems, Inc. All rights reserved. Catalog number MS.1025.0824



[www.magnumsystems.com](http://www.magnumsystems.com)

Toll Free 800.748.7000 Fax 913.362.7863  
7945 Flint Street, Lenexa, KS 66214